

Dynamic Voltage Restorer (DVR) for Voltage Sag Mitigation

Mahmoud A. El-Gammal¹, Amr Y. Abou-Ghazala², and Tarek I. El-Shennawy³

¹Dean of the Faculty of Engineering, Pharos University in Alexandria, Egypt

²Electrical Engineering Dept., Faculty of Engineering, Alexandria University, Egypt

³Alexandria National Refining and Petrochemicals Co. (ANRPC), Alexandria, Egypt
tshennawy@yahoo.com

Abstract: The Dynamic Voltage Restorer (DVR) is fast, flexible and efficient solution to voltage sag problem. The DVR is a power electronic based device that provides three-phase controllable voltage source, whose voltage vector (magnitude and angle) adds to the source voltage during sag event, to restore the load voltage to pre-sag conditions. The DVR is designed for protecting the whole plant with loads in the range of some MVA. The DVR can restore the load voltage within few milliseconds. Several configurations and control methods are proposed for the DVR. In this paper, an overview of the DVR, its functions, configurations, components, compensating strategies and control methods are reviewed along with the device capabilities and limitations.

Keywords: Dynamic Voltage Restorer (DVR), Voltage Sags, Power Quality, Custom Power

1. Introduction

The Dynamic Voltage Restorer (DVR), also referred to as the Series Voltage Booster (SVB) or the Static Series Compensator (SSC), is a device that utilizes solid state (or static) power electronic components, and is connected in series to the utility primary distribution circuit. The DVR provides three phase controllable voltage, whose vector (magnitude and angle) adds to the source voltage to restore the load voltage to pre-sag conditions [1].

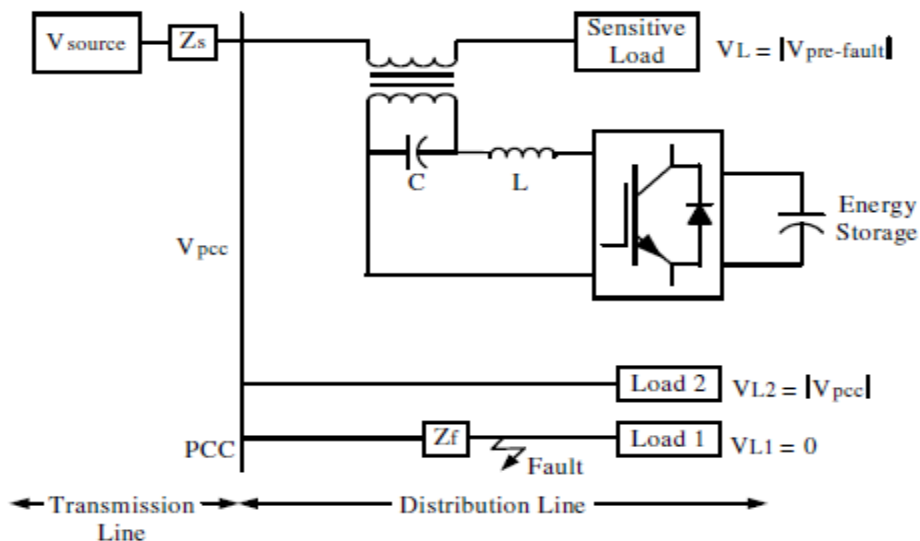

Figure 1. Role and Location of the DVR

Figure 1 is a simplified circuit for the role and location of the DVR in the distribution system. When a fault occurs on the line feeding Load 1, its voltage collapses to zero. Load 2 voltage experiences a sag which magnitude is equal to the voltage at the PCC, and the voltage of the sensitive load protected by the DVR is restored to its prefault value [2].

2. DVR Basic Configuration and Components

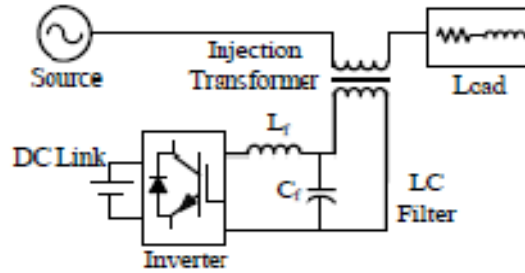

Figure 2. Basic Components of a DVR

The main components of the DVR are shown in Figure 2 and are summarized hereafter [1-5]:

A. Energy Storage Unit

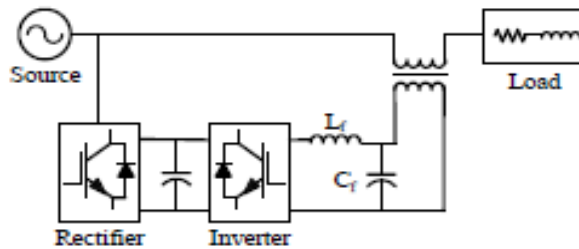

Figure 3. DVR with supply rectified energy

During a voltage sag, the DVR injects a voltage to restore the load supply voltages. The DVR needs a source for this energy. Two types of system are considered; one using stored energy to supply the delivered power as shown in Figure 2, and the other having no internal energy storage, where energy is taken from the incoming supply through a shunt converter as shown in Figure 3.

B. Inverter Circuit

The Voltage Source Inverter (VSI) or simply the inverter, converts the dc voltage from the energy storage unit (or the dc link) to a controllable three phase ac voltage. The inverter switches are normally fired using a sinusoidal Pulse Width Modulation (PWM) scheme.

Since the vast majority of voltage sags seen on utility systems are unbalanced, the VSI will often operate with unbalanced switching functions for the three phases, and must therefore treat each phase independently. Moreover, a sag on one phase may result in a swell on another phase, so the VSI must be capable of handling both sags and swells simultaneously.

Another topology of the DVR is the use of multi-inverter system in cascade. This topology will add the voltage of the single cascaded inverters in series in order to obtain the desired inverter voltage. This method gets rid of the injection transformer used in the basic configuration of the DVR. This arrangement is often called a transformer-less or multilevel or a cascade inverter DVR [6-7].

C. Filter Unit

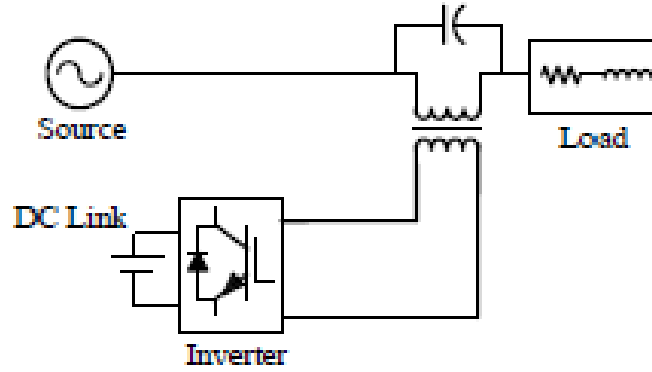

Figure 4. DVR with load side filter

The nonlinear characteristics of semiconductor devices cause distorted waveforms associated with high frequency harmonics at the inverter output. To overcome this problem and provide high quality energy supply, a harmonic filtering unit is used. These filters can be placed either in the inverter side as shown in Figure 2 or in the line side as shown in Figure 4.

D. Series Injection Transformer

Three single-phase injection transformers are used to inject the missing voltage to the system at the load bus. To integrate the injection transformer correctly into the DVR, the MVA rating, the primary winding voltage and current ratings, the turn-ratio and the short-circuit impedance values of transformers are required. The existence of the transformers allow for the design of the DVR in a lower voltage level, depending upon the stepping up ratio.

3. Compensation Strategies

Three compensation strategies are normally used for sag compensation [8-10]:

A. Pre-sag Compensation

The DVR injects the difference (missing) voltage between during-sag and pre-sag voltages to the system, the DVR must compensate for both magnitude and angle, as shown in Figure 5. It is the best solution to obtain the same load voltage as the pre-fault voltage and is best suited for loads sensitive to phase angle jumps like angle-triggered thyristors-controlled loads.

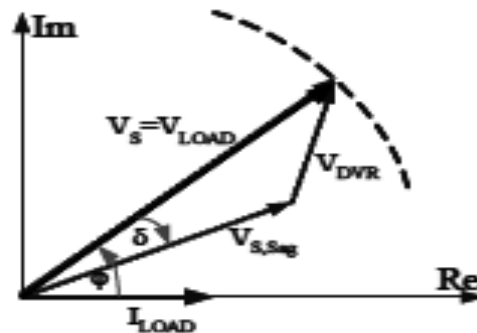

Figure 5. Pre-Sag compensation

B. In-phase Compensation

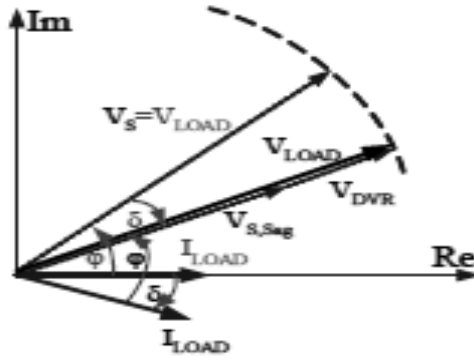

Figure 6. In-phase Compensation (Magnitude compensation only)

The injected voltage is in phase with supply voltage, as shown in Figure 6. The phase angles of the pre-sag and load voltage are different but the most important criteria for power quality that is the constant magnitude of load voltage is satisfied. In this configuration, the DVR is designed to compensate the voltage magnitude only. This method is suitable for loads that can withstand phase angle jumps.

C. Minimum (Optimized) Energy Injection

The third strategy is the minimum energy injection, which depends on maximizing the active power supplied by the network (keeping the apparent power constant and decreasing the network reactive power) by minimizing the active power supplied by the compensator (increasing the reactive power supplied by the compensator), as shown in Figure 7.

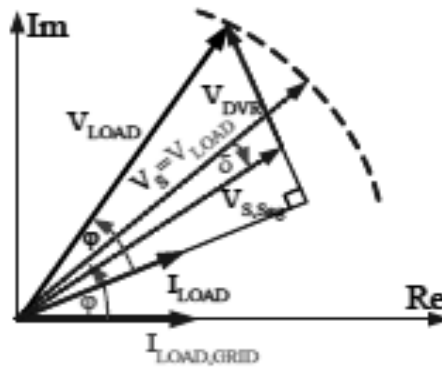

Figure 7. Energy optimized compensation

4. Sag Detection Techniques

A voltage sag detection technique detects the occurrence of the sag, the start point, the end point, sag depth (magnitude to be restored) and phase shift. Common voltage sag detection techniques are summarized as follows [11-12]:

A. Peak value method

The simplest method of monitoring the supply is to monitor the peak, or amplitude, of the supply voltage, then comparing it with a reference. A controller could be set to recognize if there is a difference greater than a specified value (10%) and switch in the inverter.

B. Root Mean Square (rms) method

The start time of the sag can be defined as the first point of V_{rms} when drops below 0.9 pu. To find the end time of the sag, search for an interval where V_{rms} drops below 0.9 pu for at least half a cycle. The recovery time is then chosen as the first point in this interval.

C. Fourier Transform (FT)

The FT is achieved through orthogonal decomposition of power system signal. In general, a trigonometrically orthogonal function set or exponential orthogonal function set is utilized. By applying FT to each supply phase, it is possible to obtain the magnitude and phase of each of the frequency components of the supply waveform. For practical digital implementation Windowed Fast Fourier Transform (WFFT) is used, which can easily be implemented in real time control system. The only drawback of this method is that it takes one cycle to return the accurate information about the sag depth and its phase, since FT uses an averaging technique.

D. Space Vector method

The three phase voltages V_{abc} are transformed into a two dimension voltage V_{dq} , which in turn can be transferred into magnitude and angle. Any deviation in any quantity reveals the occurrence of an event. Comparing these quantities with reference ones will quantify the disturbance in the dq-frame, which had to be transformed back to the abc frame. This method has no time delay, yet requires complex controller.

5. Control Techniques

A. Linear Controllers

The three main voltage controllers, which have been proposed in literature, are Feed-forward (open loop), Feedback (closed loop) and Multi-loop controller [13-18].

The feed-forward voltage controller is the primary choice for the DVR, because of its simplicity and fastness. The supply voltage is continuously monitored and compared with a reference voltage; if the difference exceeds a certain tolerance, the DVR injects the required voltage. The drawback of the open loop controller is the high steady state error.

In the feedback control, the load voltage is measured and compared with the reference voltage, the missing voltage is supplied by the DVR at the supply bus in a feedback loop. This controller has the advantage of accurate response, but it is complex and time-delayed.

Multi-loop control is used with an outer voltage loop to control the DVR voltage and an inner loop to control the load current. This method has the strengths of feed-forward and feedback control strategies, on the expense of complexity and time delay.

B. Non-linear Controllers

It appears that the nonlinear controller is more suitable than the linear type since the DVR is truly a non-linear system due to the presence of power semiconductor switches in the inverter bridge. The most non-linear controllers are the Artificial Neural Networks (ANN), Fuzzy Logic (FL) and Space Vector Pulse Width Modulation (SVPWM) [19-24].

ANN control method has adaptive and self-organization capacity. The ANN has inherent learning capability that can give improved precision by interpolation.

FL controllers are an attractive choice when precise mathematical formulations are not possible. When a FL controller is used, the tracking error and transient overshoots of PWM can be considerably reduced.

SVPWM control strategy is to adopt a space vector of the inverter voltage to get better performance of the exchange is gained in low switching frequency conditions.

6. Illustrative Case Study

In this illustrative study, the DVR control strategy is based on in-phase compensation strategy, as it will be much simpler and hence, the controller and consequently the response time will be faster. It is worth mentioning that, although the proposed DVR does not compensate for the phase angles, yet it tracks them. The sag detector block uses the traditional

FT to calculate both the magnitude and angle of the fundamental component of voltage, to make sure that the injected sine wave will be in-phase with the remaining sine wave during the sag event, to have a constructive vector addition of the DVR and the supply voltages.

In this study, a simple feed-forward controller acquires its voltage values from the source, with no feedback from the load, aiming at simple and fast response.

Figure 8 shows the block diagram of the proposed controller for the DVR.

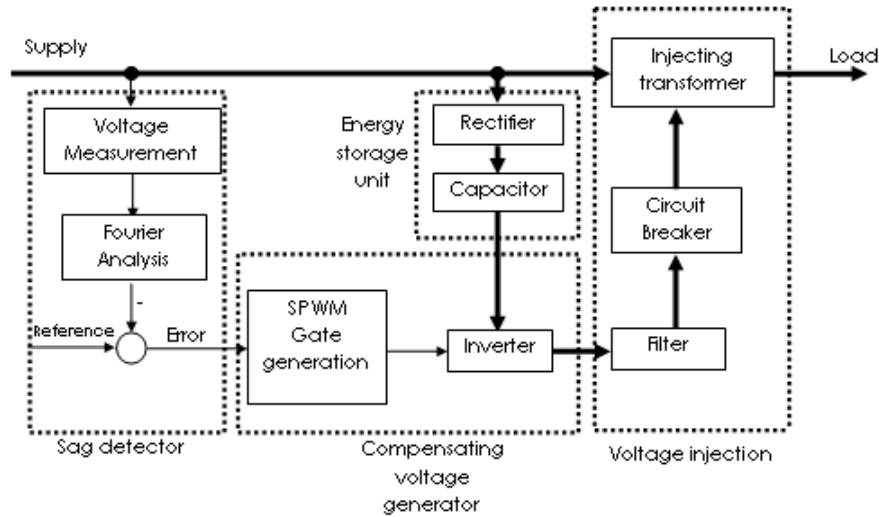

Figure 8. The block diagram of the proposed controller for the DVR

A. Sag Detector

This includes determination of the sag start instant, the depth of the sag, the phase jump angle, and the sag end instant. In this study, the FT technique is used. It requires at least one operating cycle to detect the sag start / end events.

The reference voltage is the supply 11 kV with certain tolerance. The DVR will not operate on small voltage variation events to keep the operational losses to a minimum. In this study, a tolerance of 550V (5% of rated voltage) is considered.

Computation of the compensating voltage is done using a comparator with one input as the variable system voltage and the other input being the fixed reference voltage. The comparison (subtraction) is done for magnitude only, since the compensation strategy is the In-phase method. The output of the comparator determines the voltage required to be injected by the DVR, and is called the error signal.

B. Generation of the Compensating Voltage

The inverter is the core component of the DVR, and its control will directly affect the performance of the DVR. In the proposed DVR, a sinusoidal PWM scheme will be used. The inverter used in this study is a six-pulse inverter, the carrier waveform is a triangular wave with high frequency (1000 Hz in the study). The modulating index will vary according to the input error signal.

The basic idea of PWM is to compare a sinusoidal control signal of normal 50 Hz frequency with a modulating (or carrier) triangular pulses of higher frequency. When the control signal is greater than the carrier signal, three switches of the six are turned on, and their counter switches are turned off. As the control signal is the error signal, therefore, the output of the inverter will represent the required compensation voltage.

In this study, the frequency of the carrier waveform in the PWM is chosen to be 1000 Hz. The thyristors in the inverter circuit are chosen to be of type Integrated Gate Bipolar

Transistors (IGBT) for their fast response and robust operation. The dc voltage may be utilized from alternative supply source if available. Otherwise, the line voltage is rectified and the dc energy is stored in large capacitor banks.

C. Injection of the Compensating Voltage

Once the error signal magnitude exceeds the tolerance for dynamic voltage variation, the circuit breakers close to connect the DVR into the circuit via the injecting series transformers. Compensation of any drop in the series voltage injection is mainly done to count for the voltage drop and phase shift introduced by the filter and injecting transformers. In this study, a 10% over-compensation is introduced by the controller to counteract any drops.

D. Modeling and Simulation

The performance of the DVR is evaluated by using the Matlab / Simulink program as a simulation tool. The DVR is connected in series between a three phase programmable (controllable) voltage source with 11 kV line to line rms voltage, 50 Hz, and a load of active power $P = 10$ MW and reactive power $Q = 1$ MVAR (with installation of power factor correction capacitors).

E. Results

E.1 Three phase balanced sag.

The voltage will be decreased to 70% of its normal value, for a duration of 0.4 sec from $t=0.3$ till $t=0.7$, as shown in Figure 9, where the line voltage between two phases is shown. The proposed DVR responds to this sag within one cycle (20 milliseconds), and injects the appropriate amount of missing voltage during the sag event. On detection of voltage recovery, the DVR switches off to keep conduction losses to minimum.

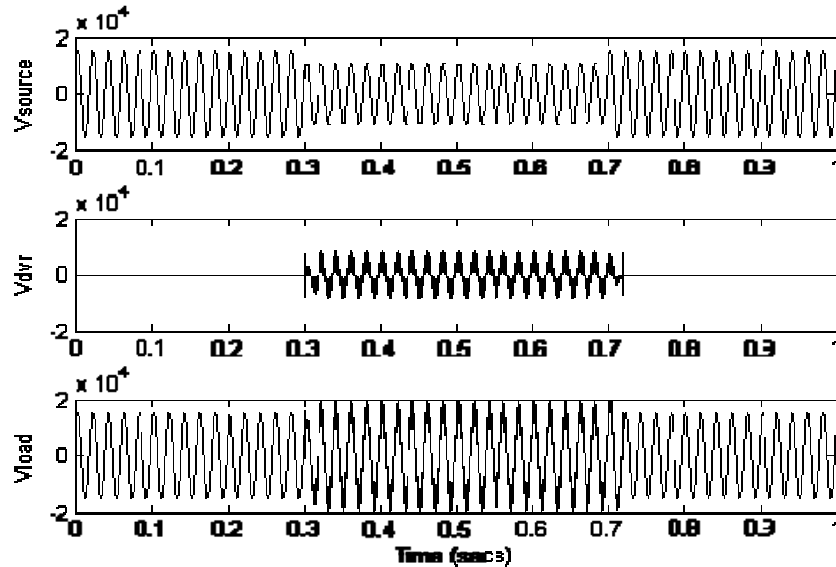

Figure 9. Three phase balanced voltage sag

E.2 Three phase unbalanced sag

To this category belong the most relevant Single-Line-To-Ground (SLG) faults. Phase A is sagged to 60% for 0.5 sec from $t=0.25$ till $t=0.75$. Note that the line voltages V_{ab} and V_{ca} will be affected, whereas V_{bc} will not. Figure 10 shows the rms representation of V_{ab} . Note how the load voltage is affected only for the cycle of sag / recovery.

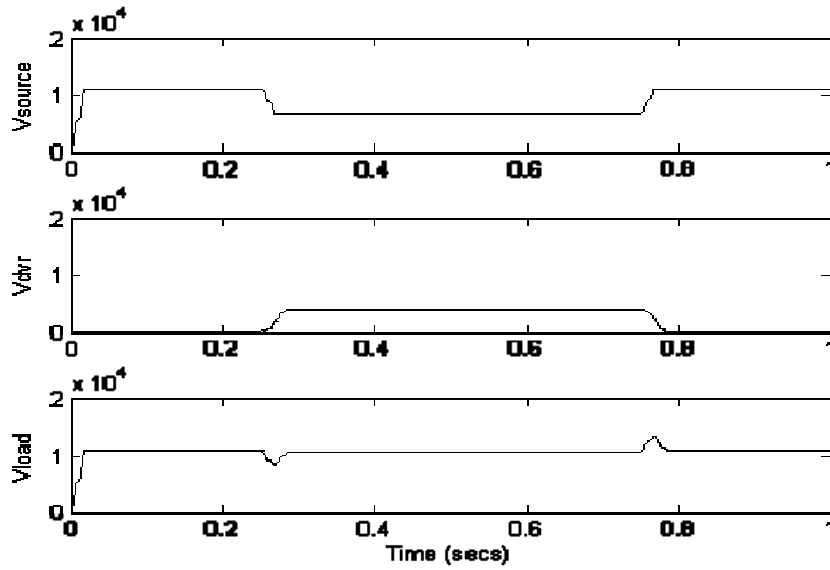

Figure 10. Single phase voltage sag

E.3 Swell

The sudden removal of large loads or application of large capacitor banks may lead to transient voltage rise. This increase in voltage (swell), although not as common as sags, may lead to insulation failure of the equipment upon times. The DVR must respond to this disturbance as well. In the simulation, voltage swells to 150% on the three phases for 0.3 sec from $t=0.3$ till $t=0.6$, as shown in Figure 11. The line voltage between two phases is shown, where the DVR responds by injecting voltage 180° shifted in phase, such that the resultant voltage will be subtracted.

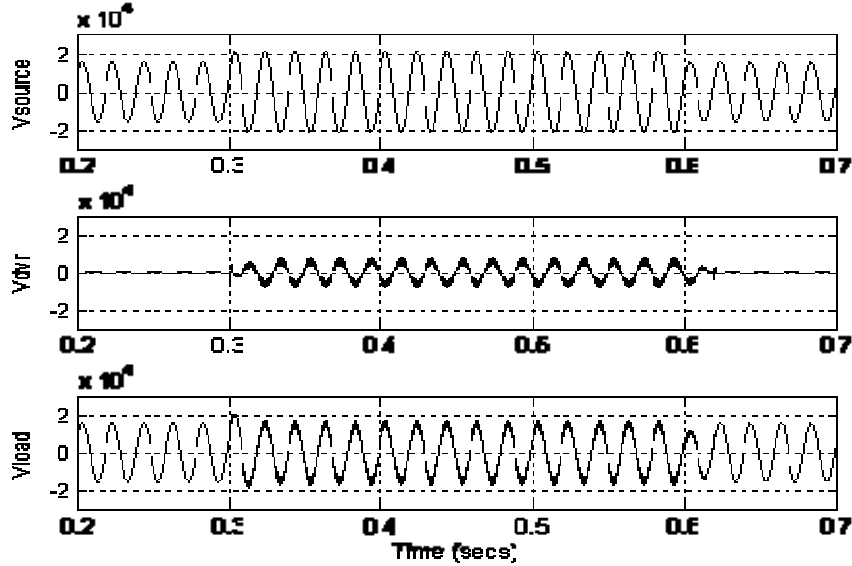

Figure 11. Voltage swell

E.4 Interruption

As a series compensator, the DVR must recognize interruptions (complete loss of power), and in this case, the DVR will be bypassed. The interruption lasts for 0.4 sec from $t=0.3$ till $t=0.7$, as shown in Figure 12.

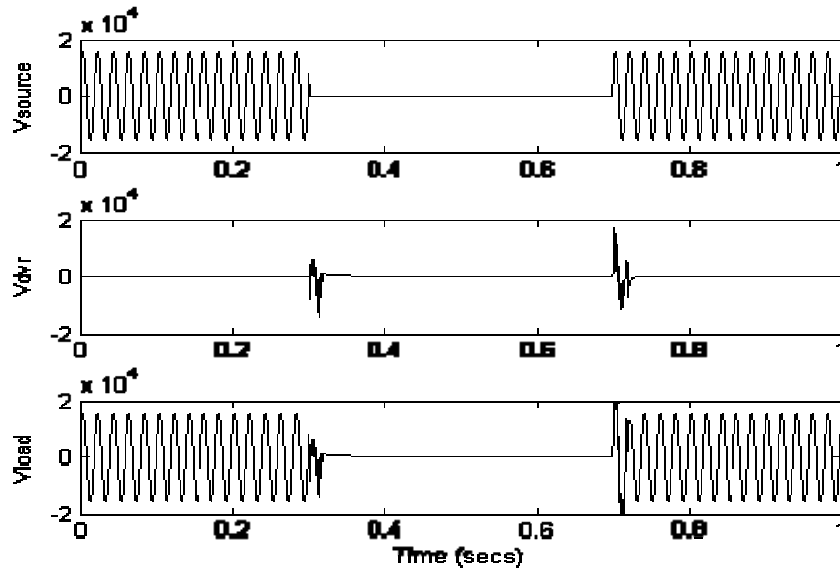

Figure 12. Three phase Interruption

7. Conclusions

In this paper, a literature review of the DVR for mitigating the problem of voltage sags is presented. The DVR performance is satisfactory in mitigating voltage sags / swells. The DVR handles both balanced and unbalanced situations without any difficulties and injects the appropriate voltage component to correct rapidly any deviation in the supply voltage to keep the load voltage balanced and constant at the nominal value. The only disadvantage of the DVR is its incapability to mitigate interruptions.

Acknowledgment

The authors would like to express their gratitude to Prof. Dr. Abdel-Moniem Moussa, Professor Emeritus at the Faculty of Engineering, Alexandria University, and President of Pharos University in Alexandria, for conducting the early stages of this paper.

References

- [1] A. Teke, M. E. Meral, L. Saribulut and M. Tumay, "Dynamic Voltage Restorers: A Literature Review", *ELEKTRIKA*, Vol. 12(1), 2010, pp. 7-13.
- [2] H.P. Tiwari and S. K. Gupta, "Dynamic Voltage Restorer against Voltage Sag", *International Journal of Innovation, Management and Technology*, Vol. 1(3), August 2010, pp. 232-237.
- [3] D. Chowdary and G. Kumar, "Mitigation of Voltage Sags in a Distribution System due to three-phase to ground Faults Using Dynamic Voltage Restorer", *Indian Journal of Engineering and Material Sciences*, Vol. 17, Apr. 2010, pp. 113-122.
- [4] C. Benachaiba and B. Ferdi, "Voltage Quality Improvement Using Dynamic Voltage Restorer", *Electrical Power Quality and Utilization Journal*, Vol. 14(1), 2008, pp. 39-46.
- [5] J. Nielsen and F. Blaabjerg, "A Detailed Comparison of System Topologies for Dynamic Voltage Restorers", *IEEE Trans. Industry Applications*, Vol. 41(5), Sep. 2005, pp. 1272-1280.

- [6] A. Visser, J. Enslin and H. Mouton, "Transformer-less Series Sag Compensation With a Cascaded Multilevel Inverter", *IEEE Trans. Industrial Electronics*, Vol. 49(4), Aug. 2002, pp. 824-831.
- [7] P. Loh, M. Vilathgamuwa, S. Tang and H. Long, "Multilevel Dynamic Voltage Restorer", *IEEE Power Electronics Letters*, Vol. 2(4), Dec. 2004, pp. 125-130.
- [8] S. Choi, J. Li and M. Vilathgamuwa, "A Generalized Voltage Compensation Strategy for Mitigating the Impacts of Voltage Sags/Swells", *IEEE Trans. Power Delivery*, Vol. 20(3), July 2005, pp. 2289-2298.
- [9] C. Meyer, C. Romaus and R. De Doncker, "Optimized Control Strategy for a Medium-Voltage DVR", *IEEE Trans. Power Electronics*, Vol. 23(6), Nov. 2008, pp. 2746-2754.
- [10] Q. Wang and S. Choi, "An Energy-Saving Series Compensation Strategy Subject to Injected Voltage and Input-Power Limits", *IEEE Trans. Power Delivery*, Vol. 23(2), Apr. 2008, pp. 1121-1131.
- [11] C. Fitzer, M. Barnes and P. Green, "Voltage Sag Detection Technique for a Dynamic Voltage Restorer", *IEEE Trans. Industry Applications*, Vol. 40(1), Jan. 2004, pp. 203-212.
- [12] B. Bae, J. Jeong, J. Lee and B. Han, "Novel Sag Detection Method for Line-Interactive Dynamic Voltage Restorer", *IEEE Trans. Power Delivery*, Vol. 25(2), Apr. 2010, pp. 1210-1211.
- [13] J. Nielsen, M. Newman, H. Nielsen and F. Blaabjerg, "Control and Testing of a Dynamic Voltage Restorer (DVR) at Medium Voltage Level", *IEEE Trans. Power Electronics*, Vol. 19(3), May 2004, pp. 806-813.
- [14] H. Kim and S. Sul, "Compensation Voltage Control in Dynamic Voltage Restorers by Use of Feed Forward and State Feedback Scheme", *IEEE Trans. Power Electronics*, Vol. 20(5), Sep. 2005, pp. 1169-1177.
- [15] M. Marei, E. El-Saadany and M. Salama, "A New Approach to Control DVR Based on Symmetrical Components Estimation", *IEEE Trans. Power Delivery*, Vol. 22(4), Oct. 2007, pp. 2017-2024.
- [16] M. Bongiorno, J. Svensson and A. Sannino, "An Advanced Cascade Controller for Series-Connected VSC for Voltage Dip Mitigation", *IEEE Trans. Industry Applications*, Vol. 44(1), Jan. 2008, pp. 187-195.
- [17] O. Abdelkhalek, A. Kechich, T. Benslimane, C. Benachaiba and M. Haidas, "More Stability and Robustness with the Multi-loop Control Solution for Dynamic Voltage Restorer", *Serbian Journal of Electrical Engineering*, Vol. 6(1), May 2009, pp. 75-88.
- [18] H. P. Tiwari, S. K. Gupta, "Dynamic Voltage Restorer Based on Load Condition", *International Journal of Innovation, Management and Technology*, Vol. 1(1), April 2010, pp. 75-81.
- [19] S. Ganesh, K. Reddy and B. Ram, "A Neuro Control Strategy for Cascaded Multilevel Inverter Based Dynamic Voltage Restorer", *International Journal of Electrical and Power Engineering*, Vol. 3(4), 2009, pp. 208-214.
- [20] P. Margo, M. Heri, M. Ashari, M. Hendrik and T. Hiyama, "Compensation of Balanced and Unbalanced Voltage Sags using Dynamic Voltage Restorer Based on Fuzzy Polar Controller", *International Journal of Applied Engineering Research*, Vol. 3(3), 2008, pp. 879-890.
- [21] H. Ezoji, A. Sheikholeslami, M. Rezaezhad and H. Livani, "A new control method for Dynamic Voltage Restorer with asymmetrical inverter legs based on fuzzy logic controller", *Simulation Modelling Practice and Theory*, Vol. 18, 2010, pp. 806-819.
- [22] C. Zhan, V. Ramachandaramurthy, A. Arulampalam, C. Fitzer, S. Kromlidis, M. Barnes and N. Jenkins, "Dynamic Voltage Restorer Based on Voltage-Space-Vector PWM Control", *IEEE Trans. Industry Applications*, Vol. 37(6), Nov. 2001, pp. 1855-1863.
- [23] H. Ding, S. Shuangyan, D. Xianzhong and J. Jun, "A Novel Dynamic Voltage Restorer and its Unbalanced Control Strategy Based on Space Vector PWM", *Electric Power and Energy Systems*, Vol. 24, 2002, pp. 693-699.

- [24] C. Zhan, A. Arulampalam and N. Jenkins, "Four-Wire Dynamic Voltage Restorer Based on a Three-Dimensional Voltage Space Vector PWM Algorithm", *IEEE Trans. Power Electronics*, Vol. 18(4), July 2003, pp. 1093-1100.



Mahmoud Ahmed El-Gammal, Received the Ph. D. degree from Tohoku University, Japan. Recently, he is the Dean of Faculty of Engineering, Pharos University in Alexandria. His recent research interests include power system analysis, voltage stability, VAR compensation, SCADA systems, power quality and custom power devices. Prof. El-Gammal is a senior member in the IEEE since 1999, a chapter member in the IEEE product safety engineering society since 2005.



Amr Yehia Abou-Ghazala, Received the Ph. D. degree from Old Dominion University, Norfolk VA, United States in 1998. Recently, he is an assistant professor of Electrical Power Engineering at the Faculty of Engineering, Alexandria University. From 2000 to 2001, he was an associate assistant professor with physical Electronics Research institute Laboratories, Old Dominion University, VA, where he was engaged in pulse power technology. His recent research interests include dynamic stability of power systems, application of artificial intelligence in electrical power systems, substation automation, power quality and electrical safety.



Tarek El-Shennawy, Received the B. Sc., the M. Sc. and the Ph. D. degrees in electrical engineering from Alexandria University, Egypt, in 1995, 2002 and 2010 respectively. From 1995 till 1998 he served as a lieutenant in the Egyptian Army, from 1998 till 2000 he worked as an instructor in the Faculty of Engineering, Alexandria University. In 2000, he joined Alexandria National Refining and Petrochemicals Co. (ANRPC), in which he is currently working as the head of electrical engineering department. His interests include power quality, protective relays and the applications of modern power equipment in industrial distribution systems. Dr. El-Shennawy is an IEEE member since 2005.